

**Montageanleitung
Mounting Instructions
Instructions de montage
Istruzioni di montaggio
Instrucciones de montaje**

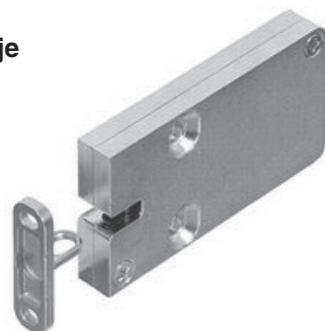

**Möbelverriegelung EFL 3 / EFL 3C
Furniture Lock EFL 3 / EFL 3C
Fermeture pour meubles EFL 3 / EFL 3C
Serratura di mobili EFL 3 / EFL 3C
Cerrojo de mueble EFL 3 / EFL 3C**



Art.-Nr./art. no./Réf./n° articolo/Ref. 237.56.304 / 237.56.305

**1. Lieferumfang / Scope of delivery / Contenu de la fourniture /
Dotazione di fornitura / Volumen de envío**

EFL 3 / EFL 3C

EFL 3	EFL 3C	
Verriegelung EFL 3 / Furniture Lock EFL 3 / Fermeture pour meubles EFL 3 / Serratura di mobili EFL 3 / Cerradura de mueble EFL 3	Möbelverriegelung EFL 3C mit Türsensor / Furniture Lock EFL 3C with door sensor / Fermeture pour meubles EFL 3C avec capteur de porte / Serratura di mobili EFL 3C con sensore porta / Cerradura de mueble EFL 3C con sensor puerta	1
Schließstück / Locking piece / Boulon de fermeture / Perno di chiusura / Cerrojo	Schließstück für EFL 3C mit Magnet / Locking piece with magnet / Boulon de fermeture avec magnétique / Perno di chiusura con magnete / Cerrojo con magneto	2 2*

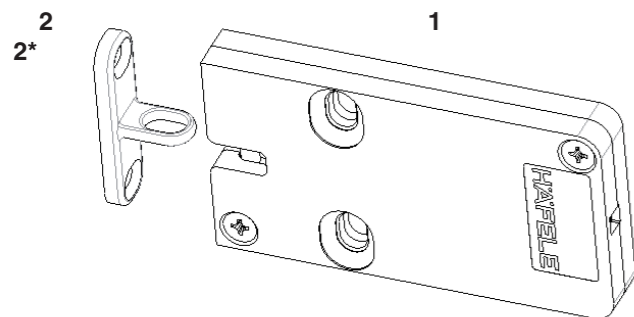

2. Zubehör / Accessories / Accessoires / Accessori / Accessoires

separat zu bestellen / to be ordered separately / a commander séparément /
a ordinare separato / a pedir separatamente

	Art.-Nr. / art. no. / Réf. / n° articolo / Ref.
Montagelehre für EFL 3 / Mounting gauge for EFL 3 / Gauge de montage pour EFL 3 / Calibro per il montaggio per EFL 3 / Calibre de montaje por EFL 3	001.25.000
Anreißlehre für Schließstück / Marking jig for locking piece / Gabarit de tracage pour bou- lon de fermeture / Calibro a tracciare per il perno di chiusura / Calibre de trazar el cerrojo	237.56.330
Schließstück für Glasmontage / Locking piece for glass mounting / Boulon de fermeture pour montage vitré / Perno di chiusura per montaggio vitreo / Cerrojo per montaje vidrio	237.56.315
Anschlusskabel	siehe Seite 2

3. Maße / Dimensions / Dimensions / Misure / Medidas

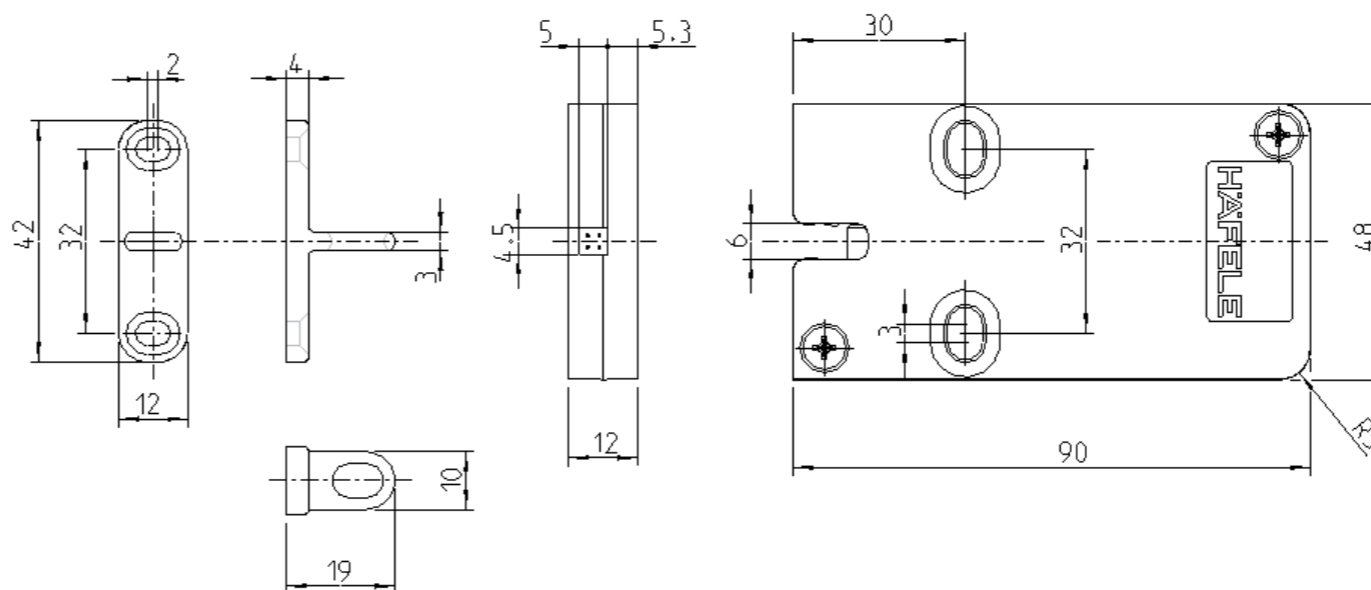

**4. Abstand Schließstück-EFL 3 / Distance
locking piece - EFL 3 / Distance du boulon de
fermeture - EFL 3 / Distanza di perno di chiusu-
ra - EFL 3 / Distancia del cerrojo - EFL 3**

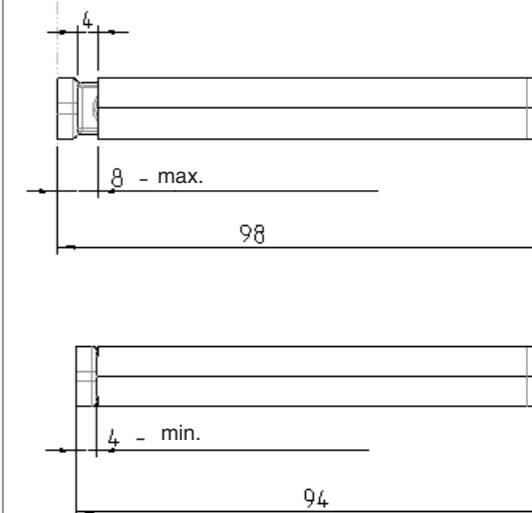

**5. Montagevarianten Schließstück / Locking piece mounting options / Options de la
montage du boulon de fermeture / Alternative del montaggio del perno di chiusura /
Opciones del montaje del cerrojo**

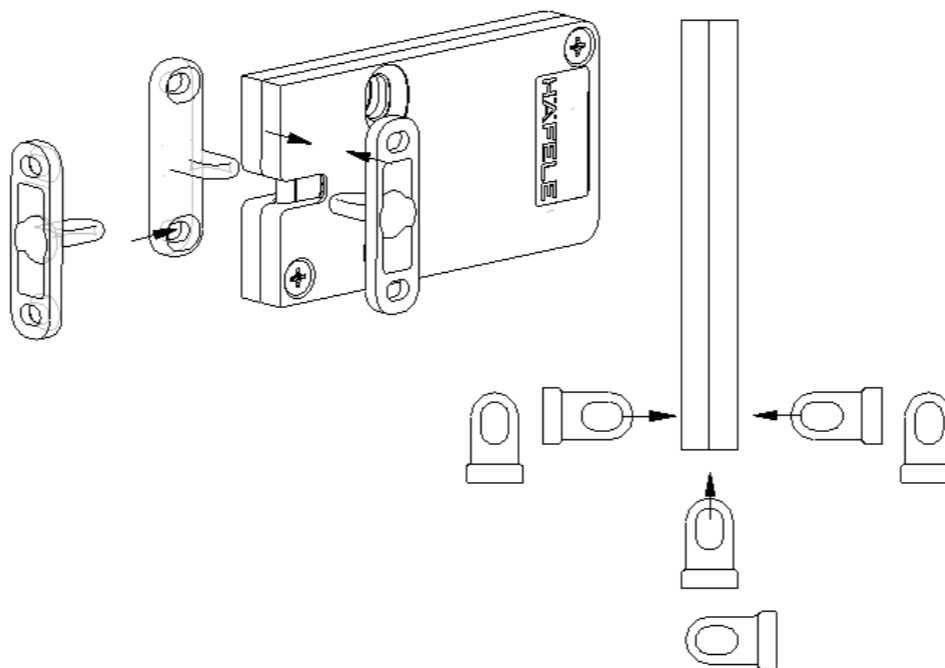

**7. Tür aufliegend / Overlay door / Port à plat / Porta a battuta sovrapposte /
Puerta sobrepuesta**

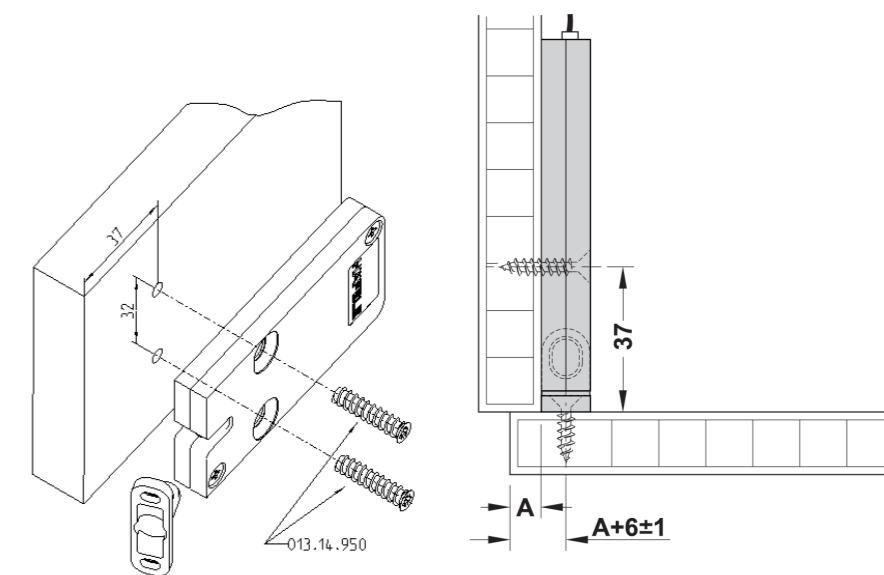

8. Tür einliegend / Inset door / Port affleurante / Porta a filo / Puerta enrasada

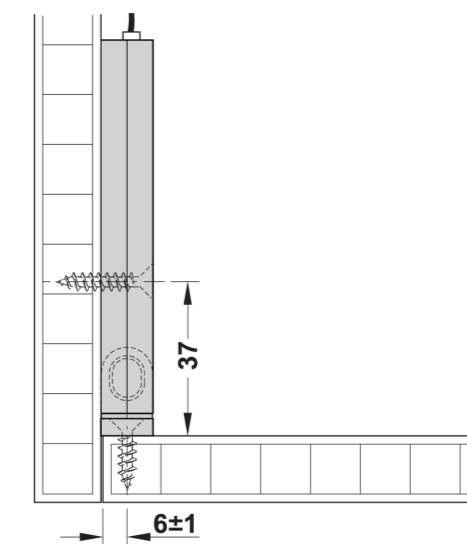

**6. Einbaubedingungen / Installation conditions / Conditions de l'installation / Condi-
zioni del installazione / Condiciones de la instalación**

Nur im Innenbereich / For interior use only / Seulment dans domaines internes / Solo nel
ambiente dentro / Solo en zonas interiores

T_{amb} = 0 – 50°C

Class = IP 30

H_{rel} = 90% non condensing, max.

Art.-Nr. / art. no. / Réf. / n° articolo / Ref. 300-050-00010
 Maße in mm – Dimensions in mm – Mesure in mm – Medidas en mm

9. Schubkasten, EFL rückseitig montiert / Drawer, EFL rear mounted / Tiroir, EFL montée arrière / Cassetto, EFL montato dietro / Cajon, EFL montada detrás

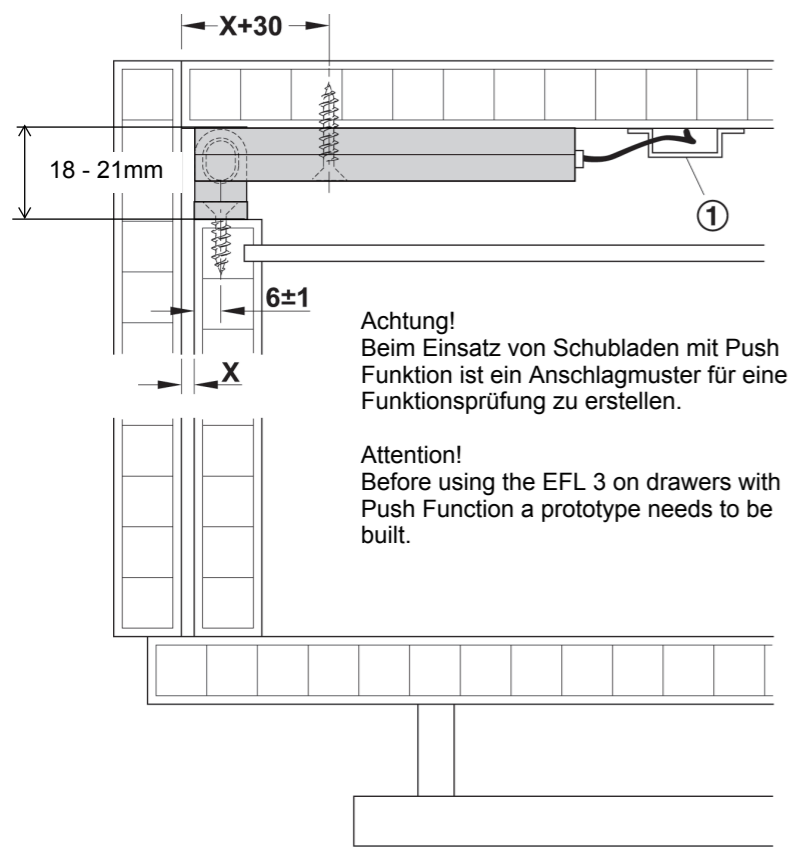

10. Schubkasten, EFL seitlich aufgesetzt / Drawer, EFL laterally surface mounted / Tiroir, EFL montée latéral, su-jacent / Cassetto, EFL montato a lato, sopra superficie / Cajon, EFL montada lateral, sobrepuesta

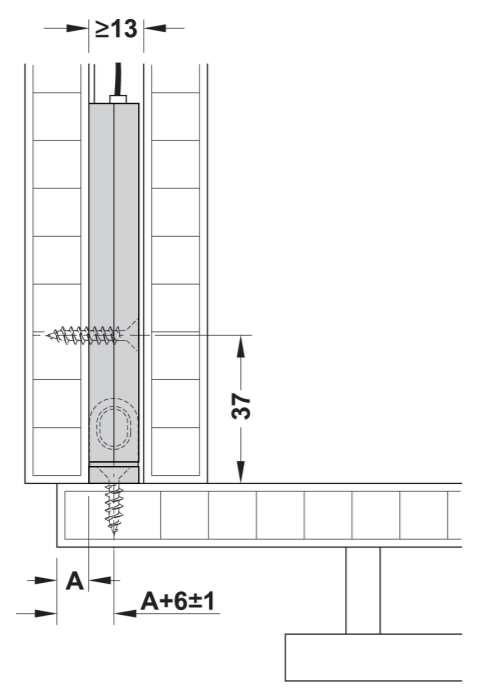

11. Anschluss an DFT Tag-it ISO / Connecting with DFT Tag-it ISO / Connexion a DFT Tag-it ISO / Coessione con DFT Tag-it ISO / Conexión con DFT Tag-it ISO

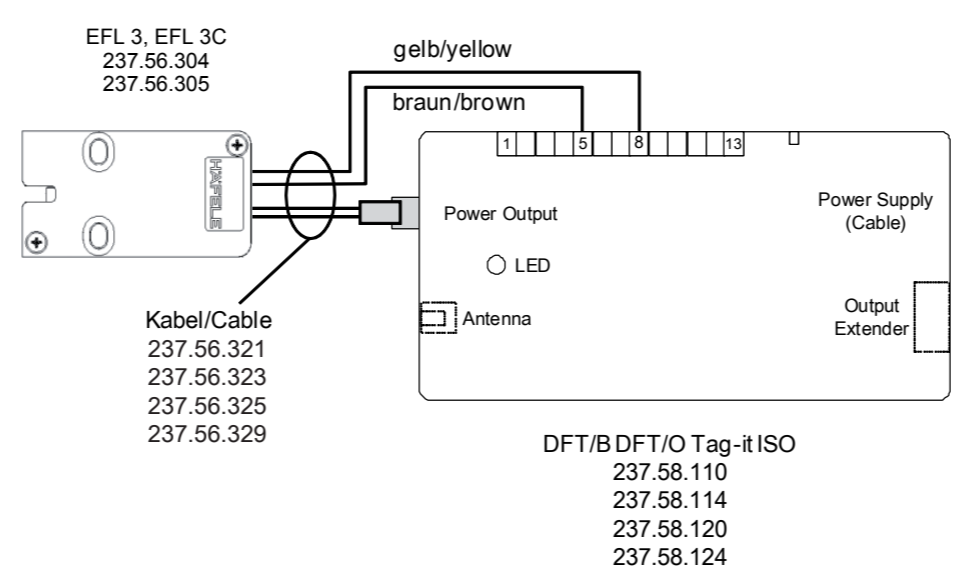

12. Anschluss an ein Dialock Wandterminal / Connecting with Wall Terminal WT / Connexion a Terminal Mural WT / Coessione con Terminale A Parete WT / Conexión con Terminal Mural WT

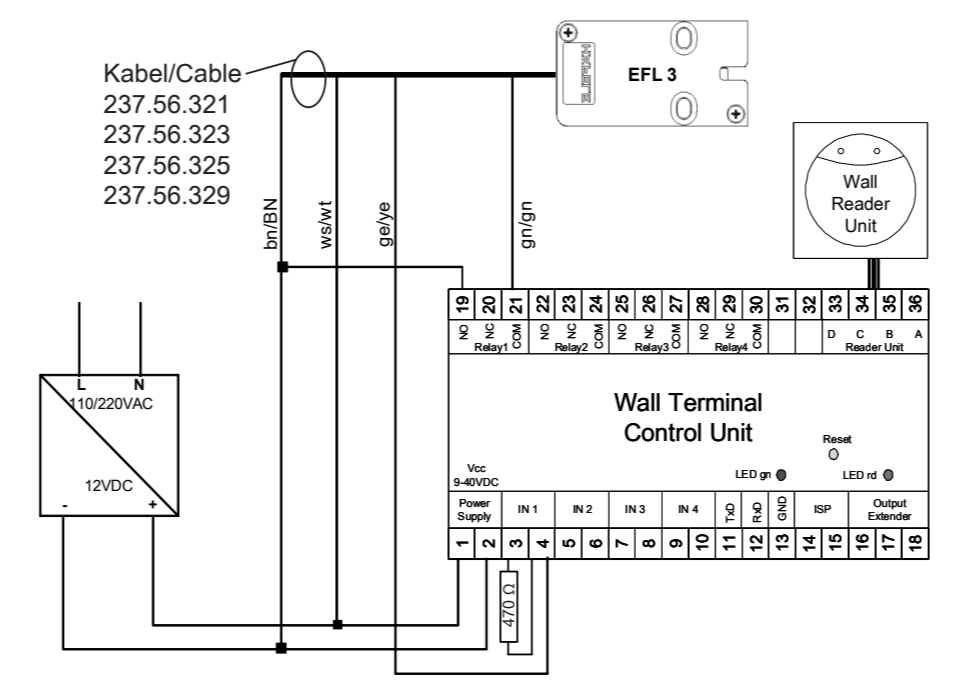

13. Anschluss an DFT Tag-it ISO V2 / Connecting with DFT Tag-it ISO V2 / Connexion a DFT Tag-it ISO V2 / Coessione con DFT Tag-it ISO V2 / Conexión con DFT Tag-it ISO V2

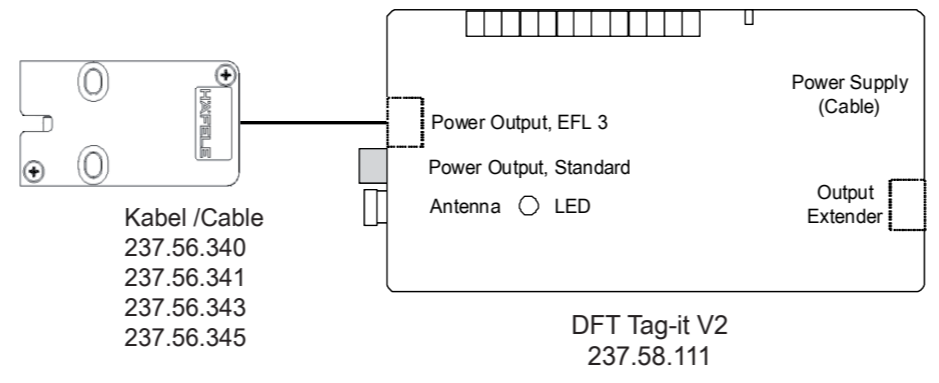

14. Mehrere EFL 3 an DFT Tag-it ISO V2 / Multiple EFL 3 with DFT Tag-it ISO V2 / Plusieurs ELF 3 avec DFT Tag-it ISO V2 / Alcuni EFL 3 con DFT Tag-it ISO V2 / Varios EFL 3 con DFT Tag-it ISO V2

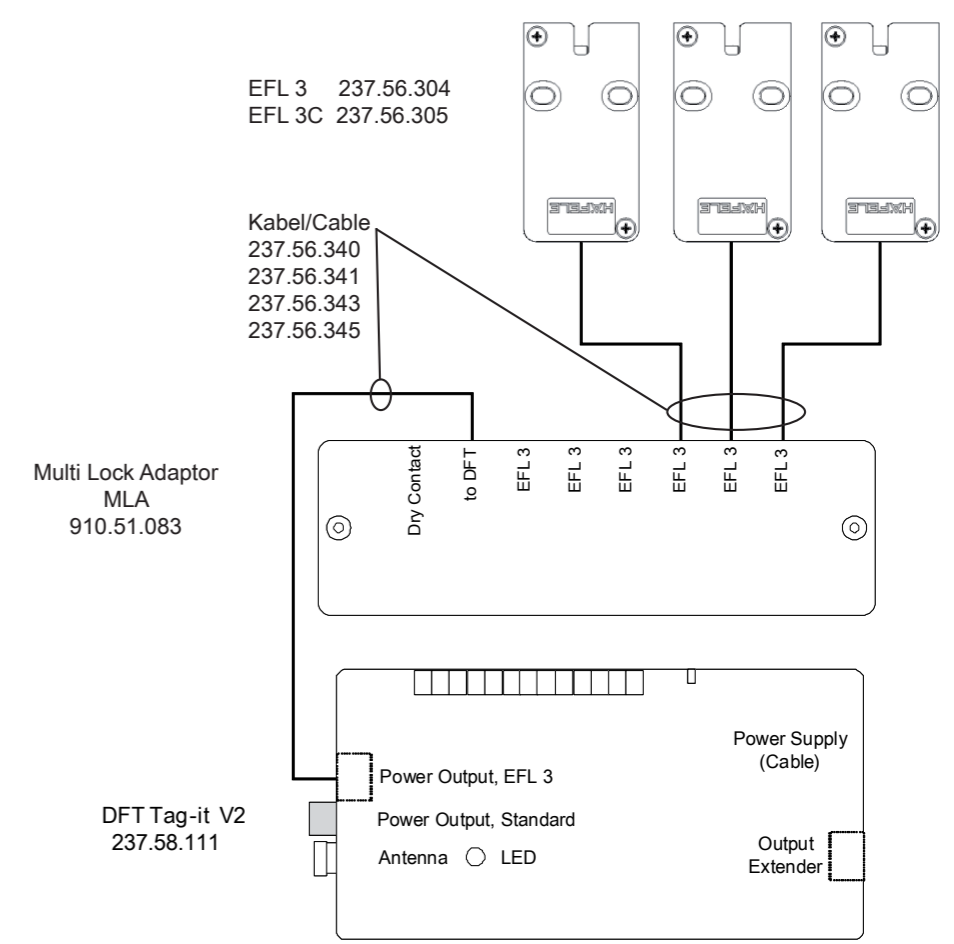

15. Anschlussbelegung EFL 3/3C / Pin assignment EFL 3/3C / Raccordement du EFL 3/3C / Attacco EFL 3/3C / Conexión EFL 3/3C

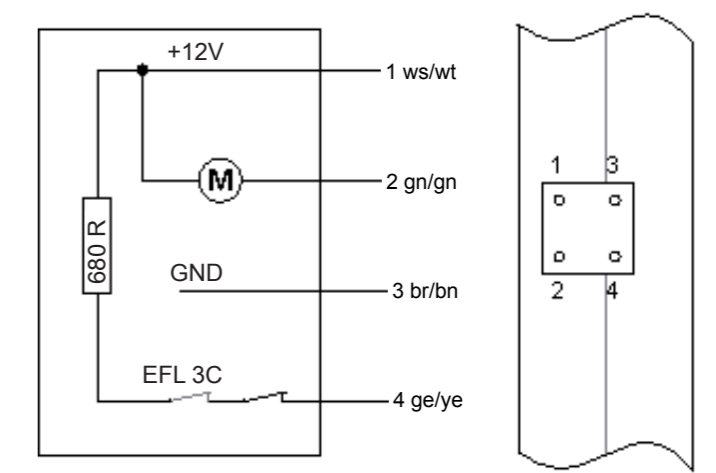

16. Steckerausrichtung am EFL 3 / Connector orientation EFL 3 / Orientation du connecteur EFL 3 / Orientamento della spina EFL / Orientación de enchufe EFL 3

